

■ WÖHR Bikesafe 885/16 (122 Stellplätze), Lenkerbreite 76 cm

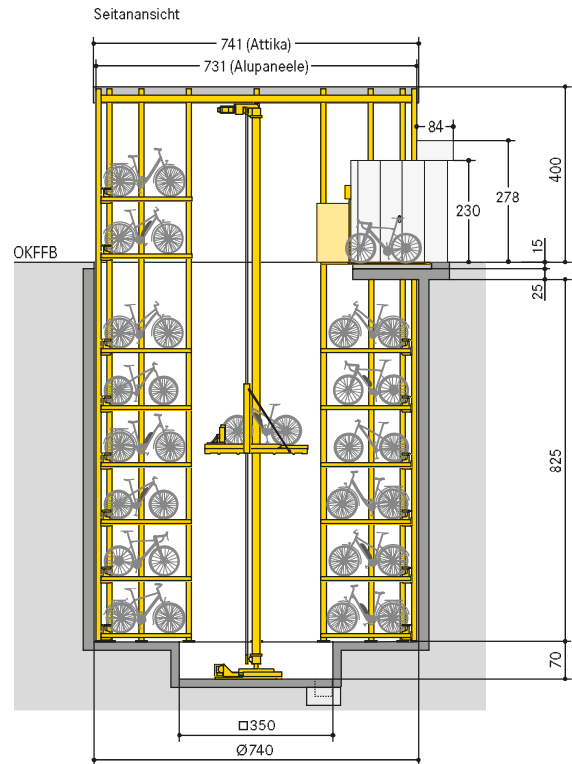

Hinweis: Wenn möglich, eine Zugangstür im Schachtbereich vorsehen.

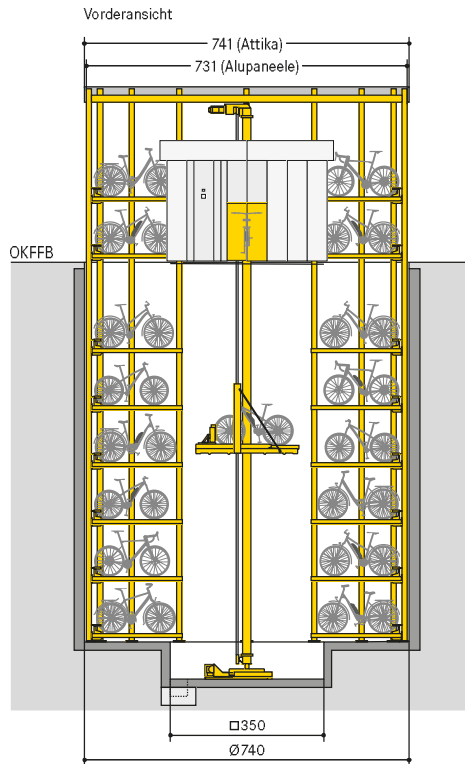
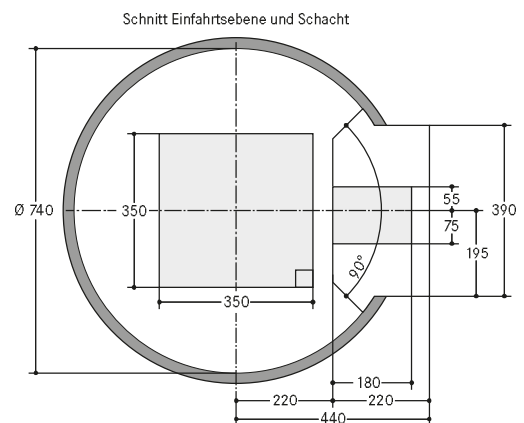
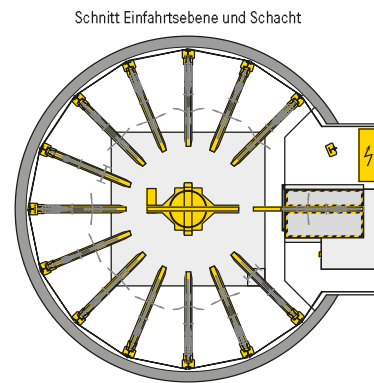
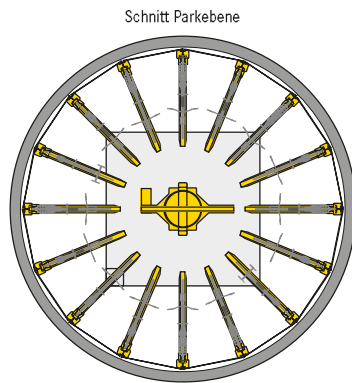

■ WÖHR Bikesafe 885/16 (122 Stellplätze), Lenkerbreite 83 cm

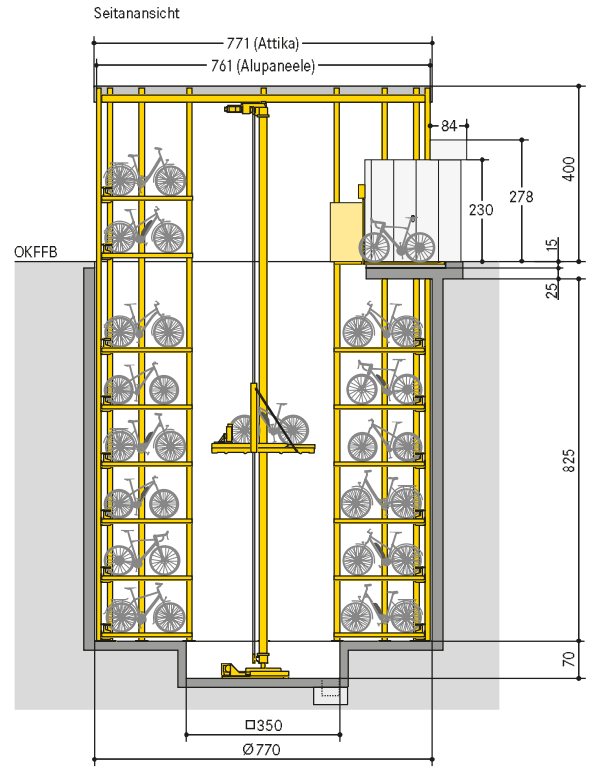
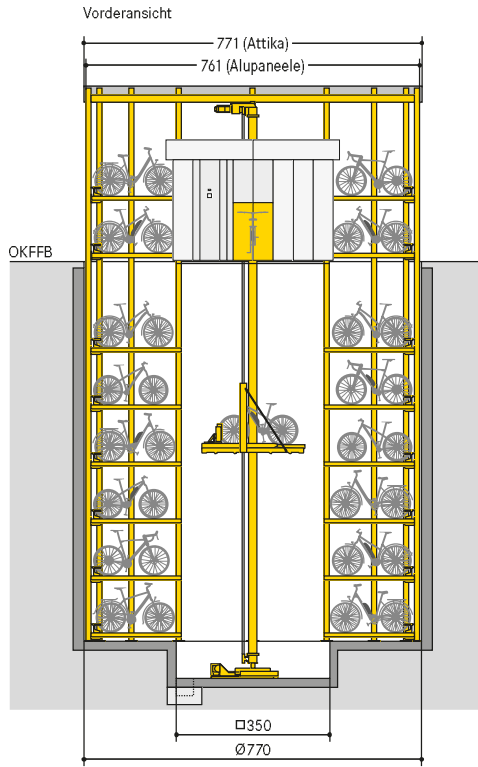

Hinweis: Wenn möglich, eine Zugangstür im Schachtbereich vorsehen.

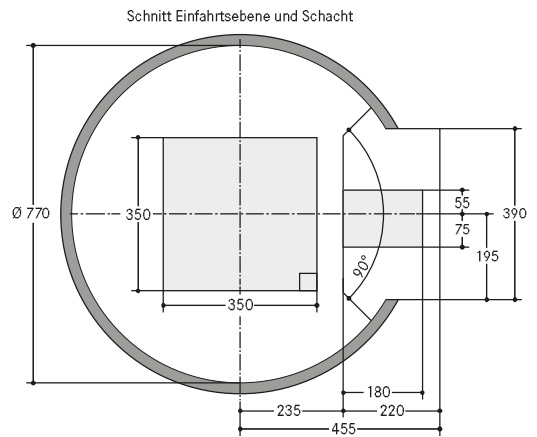
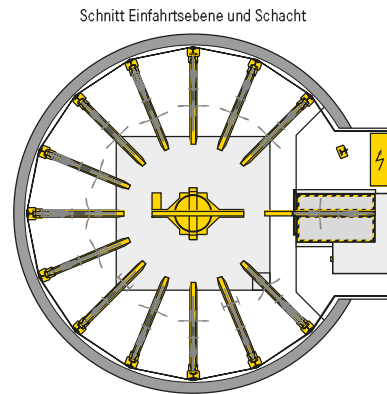
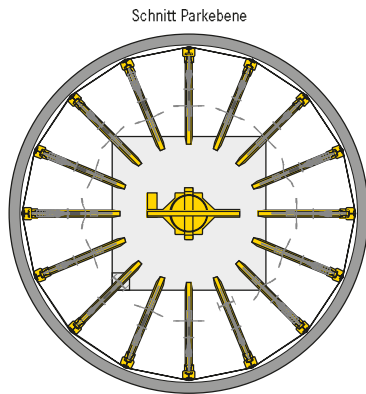

■ WÖHR Bikesafe 885/20 (154 Stellplätze), Lenkerbreite 76 cm

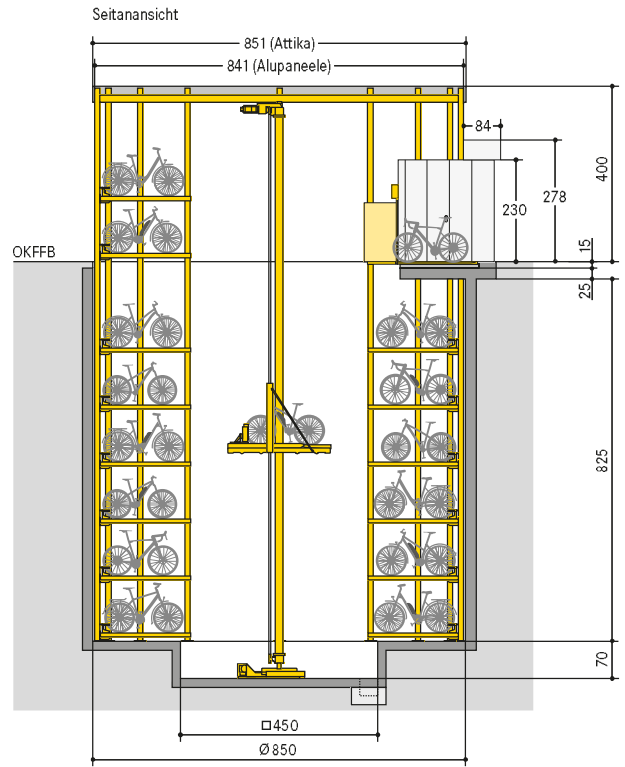
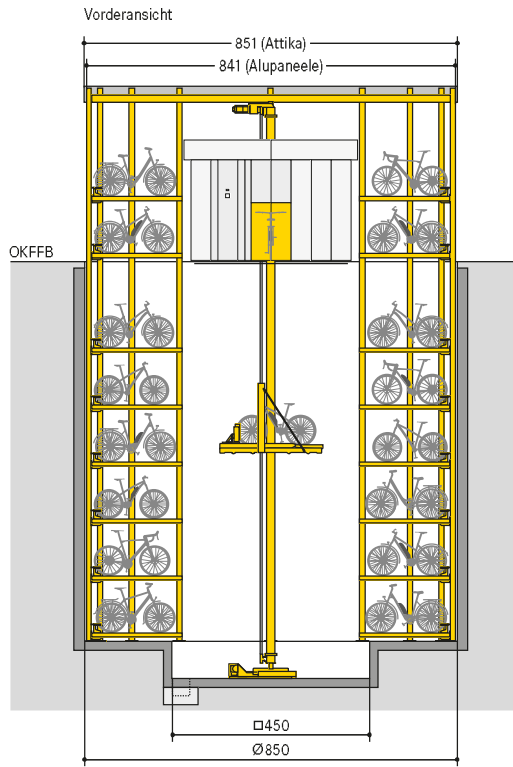

Hinweis: Wenn möglich, eine Zugangstür im Schachtbereich vorsehen.

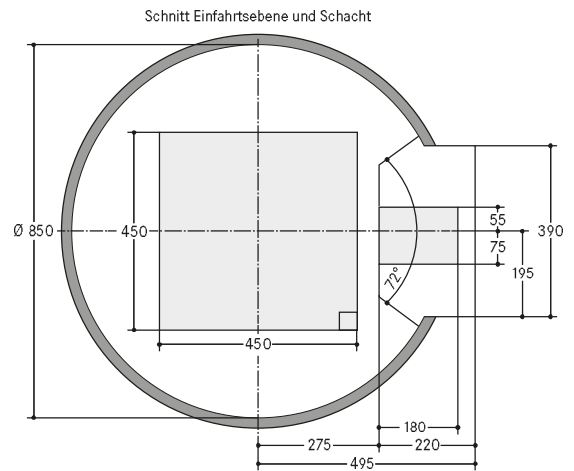
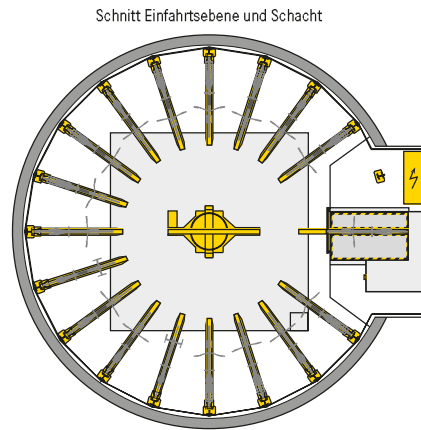
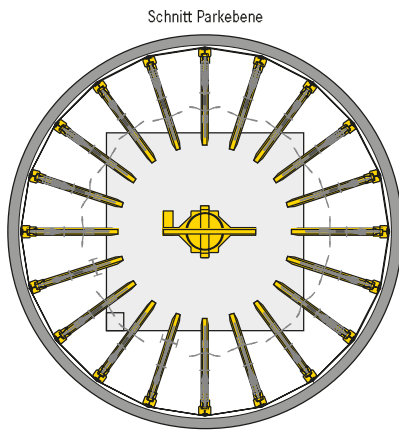

■ WÖHR Bikesafe 885/20 (154 Stellplätze), Lenkerbreite 83 cm

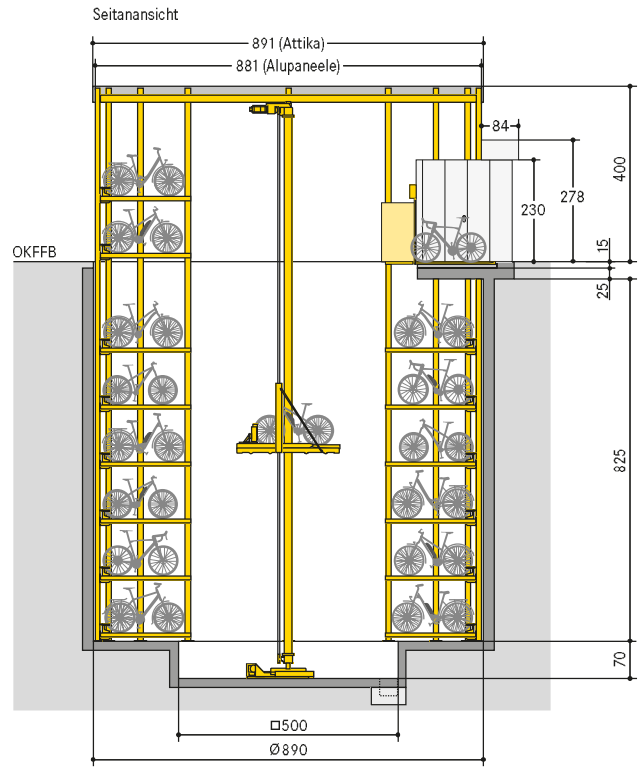
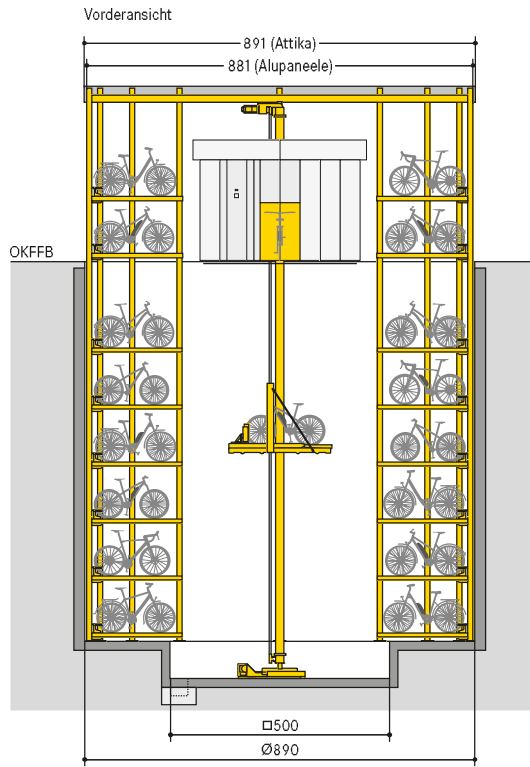

Hinweis: Wenn möglich, eine Zugangstür im Schachtbereich vorsehen.

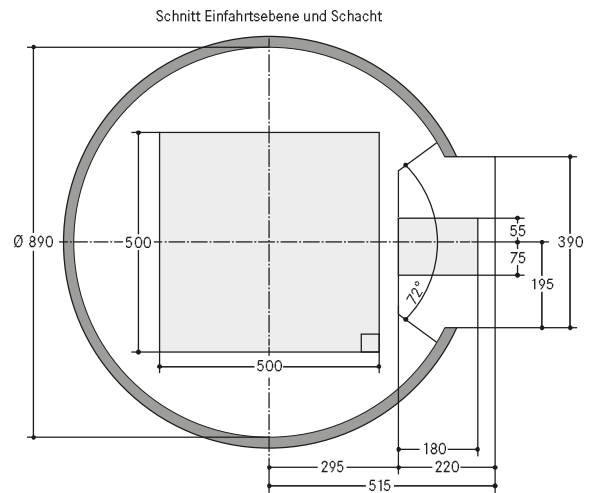
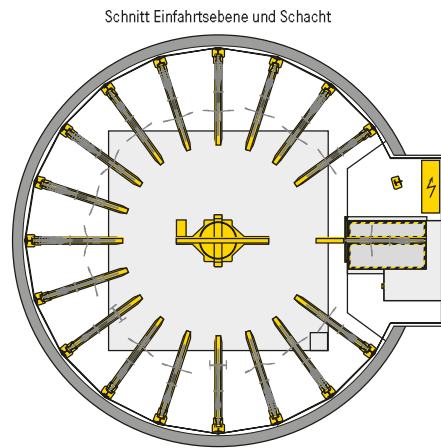
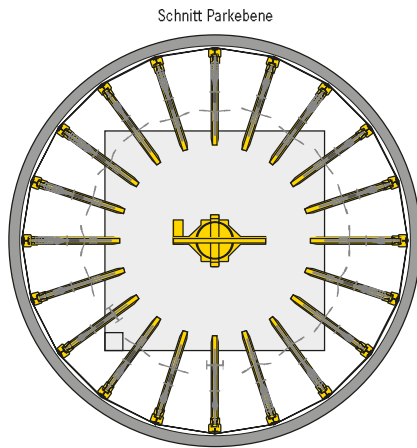

■ WÖHR Bikesafe 885/24 (186 Stellplätze), Lenkerbreite 76 cm

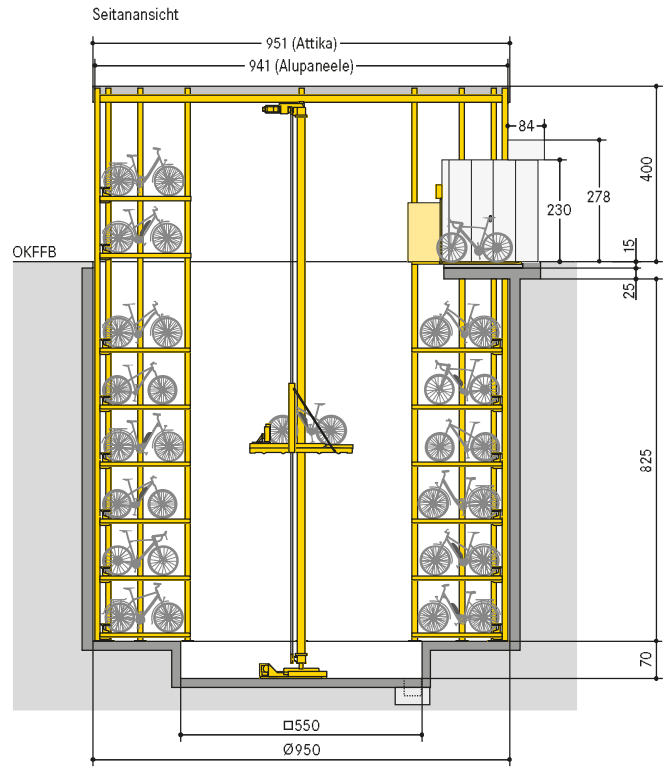
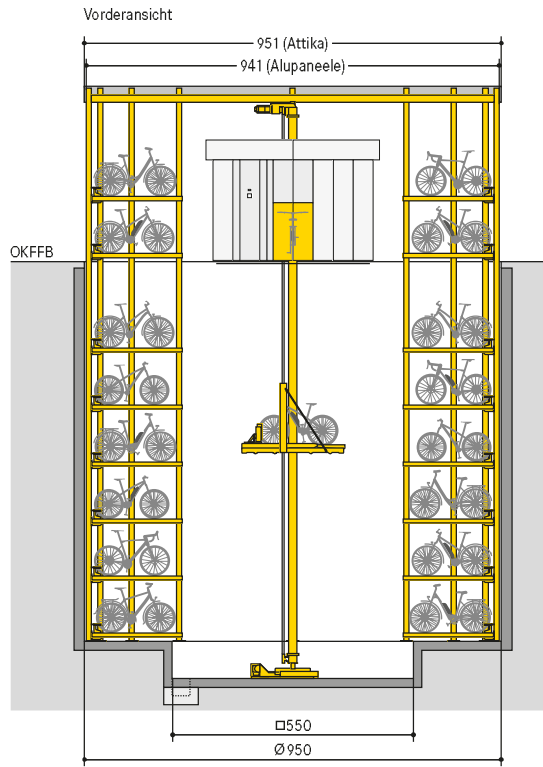

Hinweis: Wenn möglich, eine Zugangstür im Schachtbereich vorsehen.

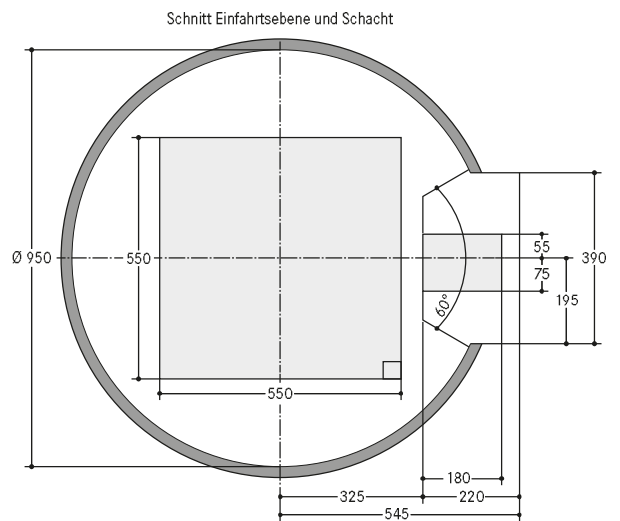
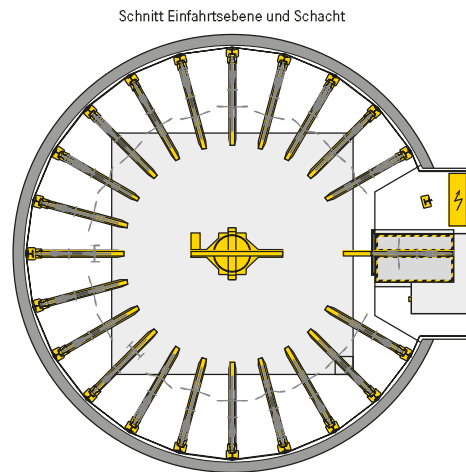
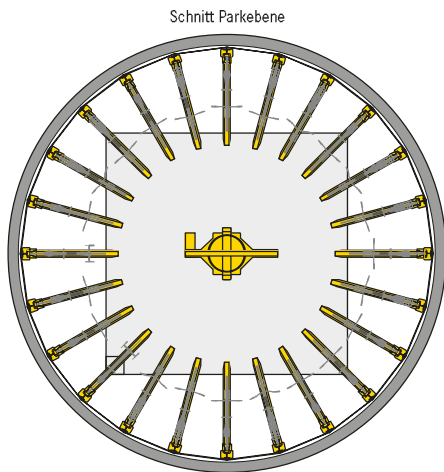

■ WÖHR Bikesafe 885/24 (186 Stellplätze), Lenkerbreite 83 cm

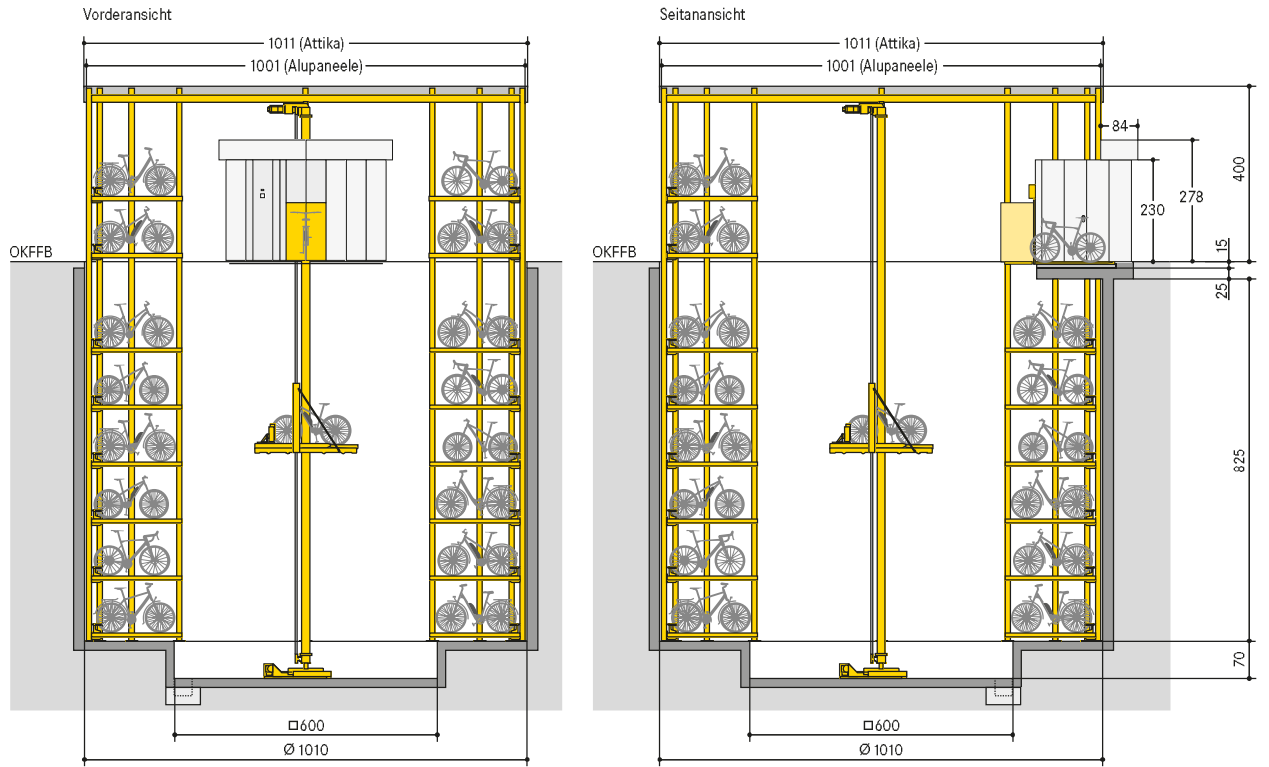

Hinweis: Wenn möglich, eine Zugangstür im Schachtbereich vorsehen.

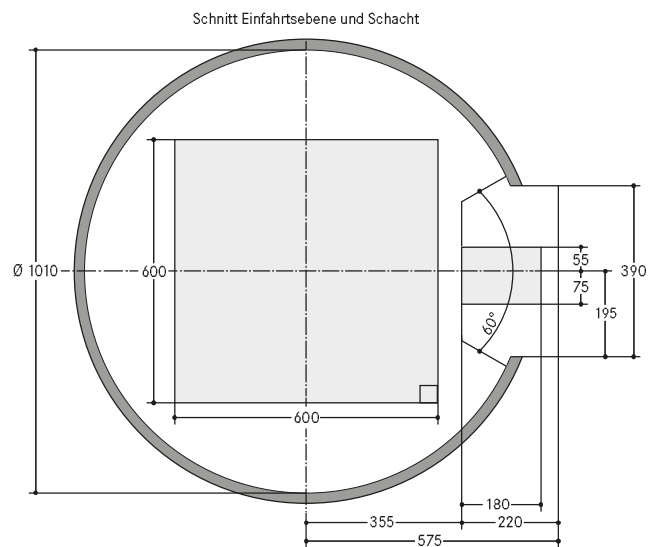
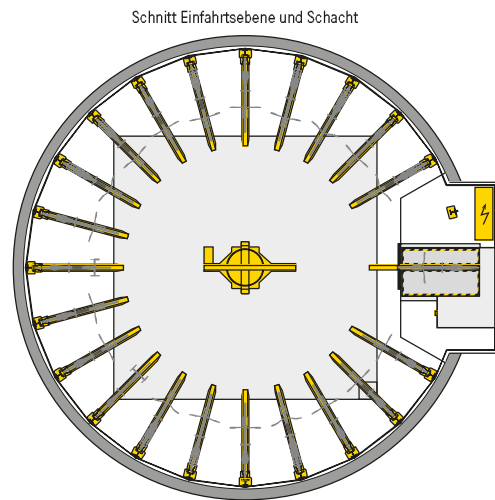
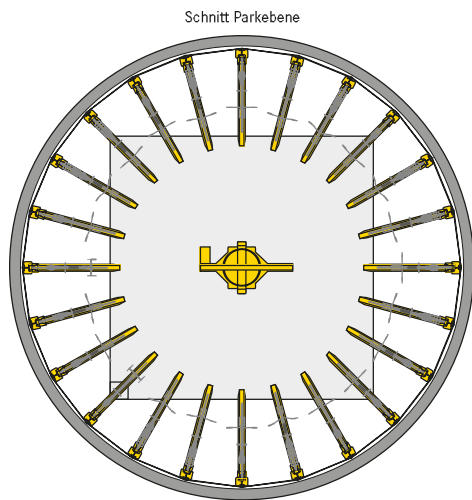

■ Masse

- alle Masse sind Mindestfertigmasse
- Toleranzen nach VOB Teil C (DIN 18330, 18331) sowie DIN 18202 zusätzlich berücksichtigen
- alle Masse in cm